



EstesRockets.com

# LIBERTY STAR™

0691

AGES  
**10+**



Skill Level

**BEGINNER**

## MODEL ROCKET INSTRUCTIONS

KEEP FOR FUTURE REFERENCE

**IMPORTANT:** Please record date found on decal and keep for future reference. \_\_\_\_\_

### CAUTION:

May not apply to all kits. For safe handling of plastic cement, epoxy, spray adhesive, CA glue, CA accelerator, paint/finishing materials, see manufacturer's warnings and follow instructions for use. To avoid injury, use extreme caution when using hobby knife, scissors, drills, and any cutting tools.

### SUPPLIES



CLEAR TAPE



PLASTIC CEMENT

072936-3546C  
Engine Mount

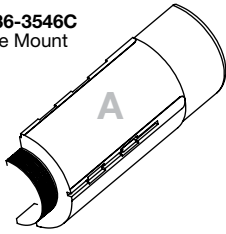

072936-3546C  
Engine Mount

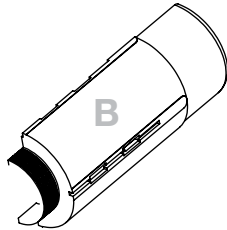

065249  
Launch Lug

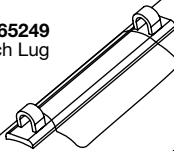

E

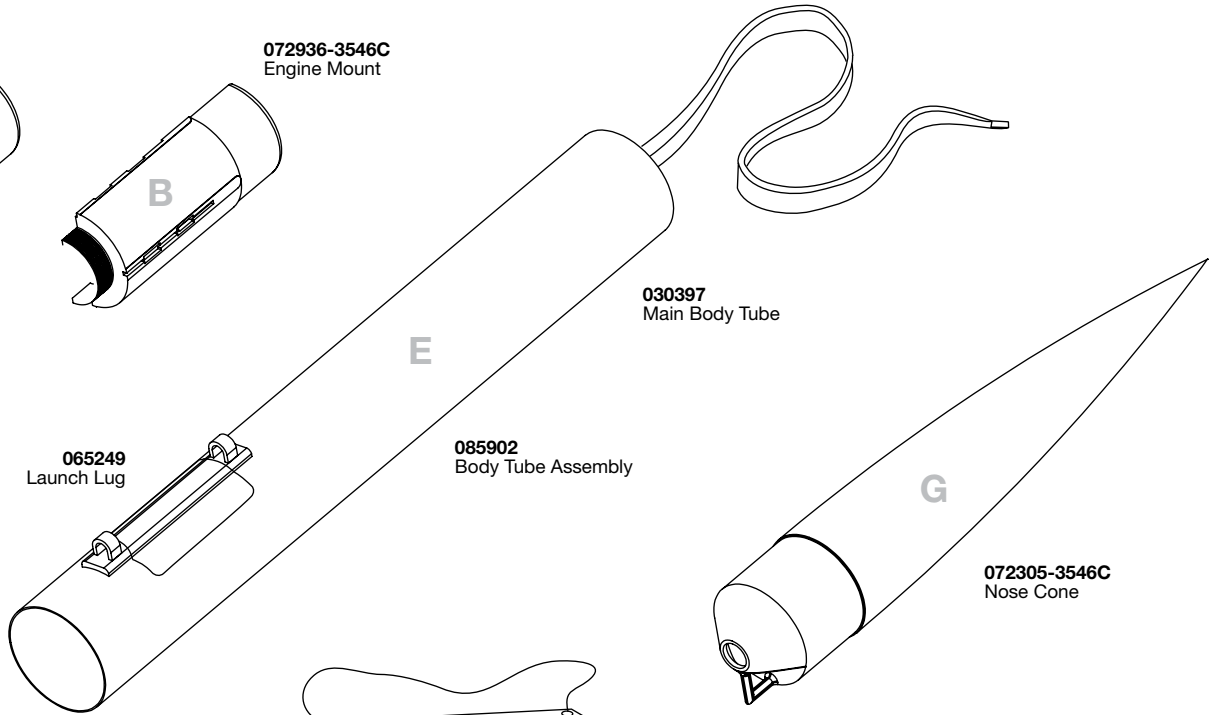

030397  
Main Body Tube

085902  
Body Tube Assembly

G

072305-3546C  
Nose Cone

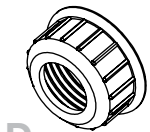

072938-3546C  
Engine Retainer Cap

H

035806  
15" Parachute

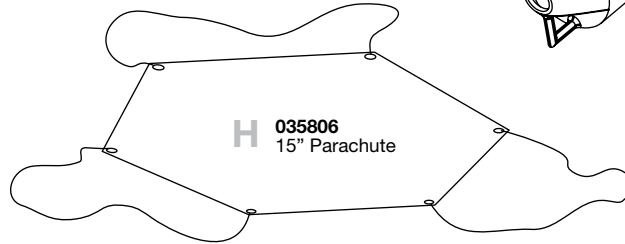

C

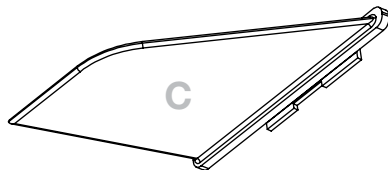

072939-286C  
Fin

C

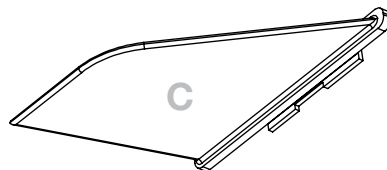

072939-WHT  
Fin X3

090001-0691  
Self-Stick Decal Sheet



## ASSEMBLE FIN CAN

1. Apply plastic cement to the edges of one **A** part as shown.

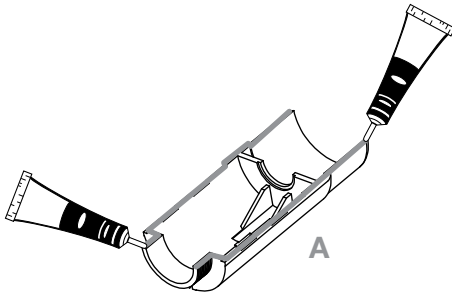

2. Join both **A** parts together.

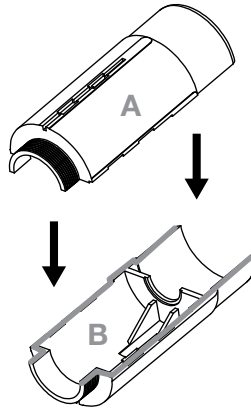

3. Hold together until cement starts to set.

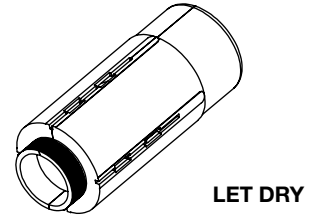

4. Insert the fins into the slots and slide upward towards the top of the fin can. Repeat for all fins.

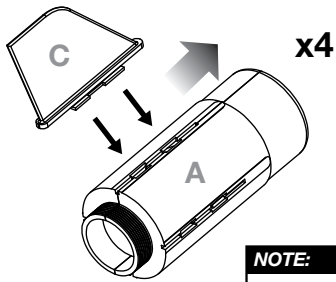

**NOTE:**

After inserting fin into slots, push upward until the bottom of the fin edge is flush with bottom of fin can.

5. Screw the Retainer Cap onto the fin can as shown.

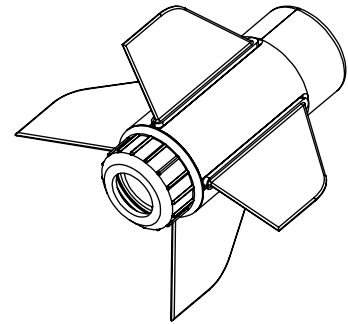
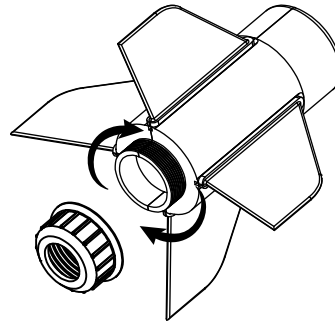

## ATTACH BODY TUBE

1. Apply plastic cement to the inner portion of the body tube **E** as shown.

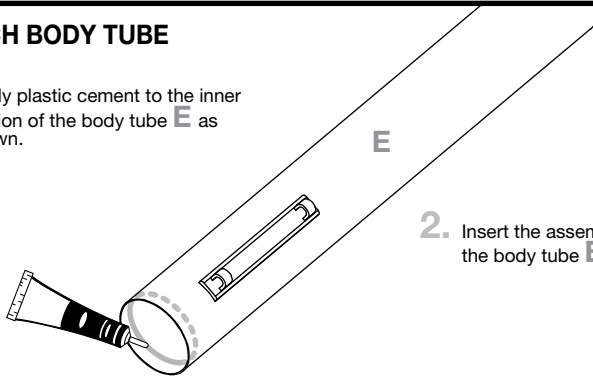

2. Insert the assembled fin can into the body tube **E** as shown.

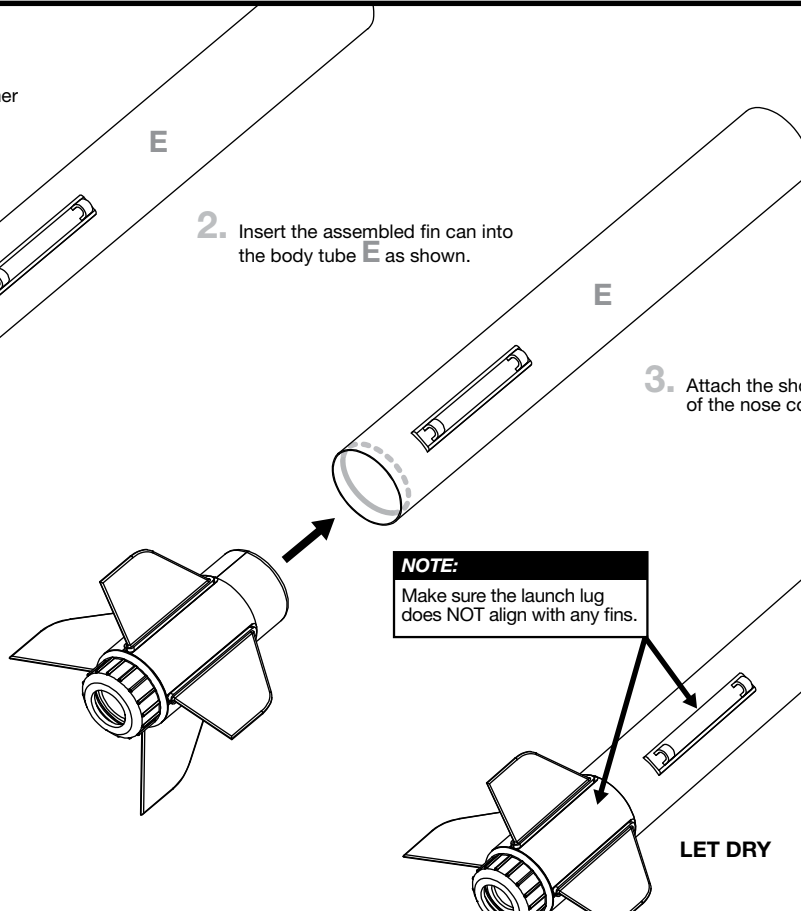

3. Attach the shock cord to eyelet of the nose cone and tie double knot.

**DOUBLE KNOT**

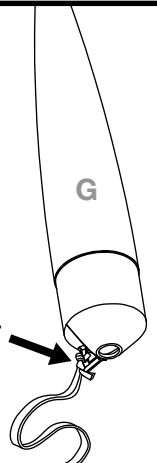

## PREPARE RECOVERY SYSTEM

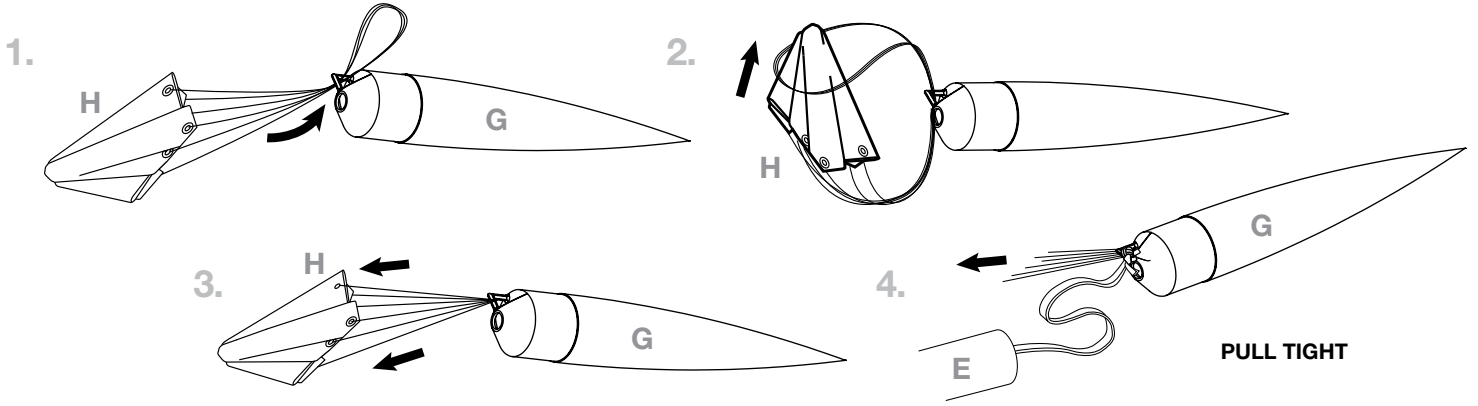

## PREPARE FLIGHT RECOVERY

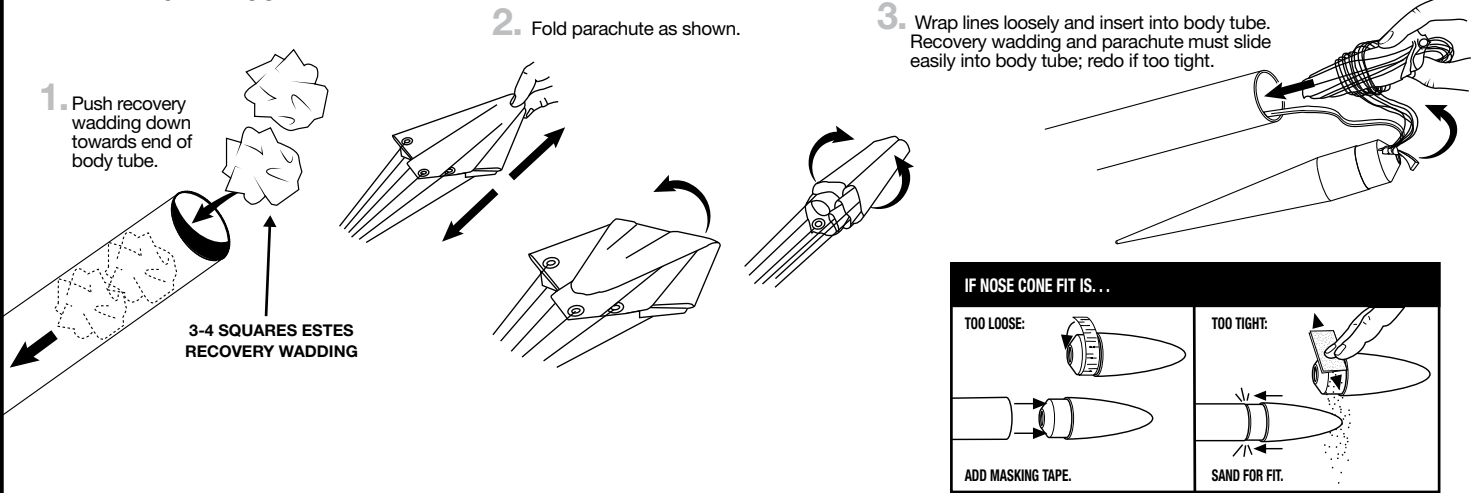

## PREPARE ENGINE

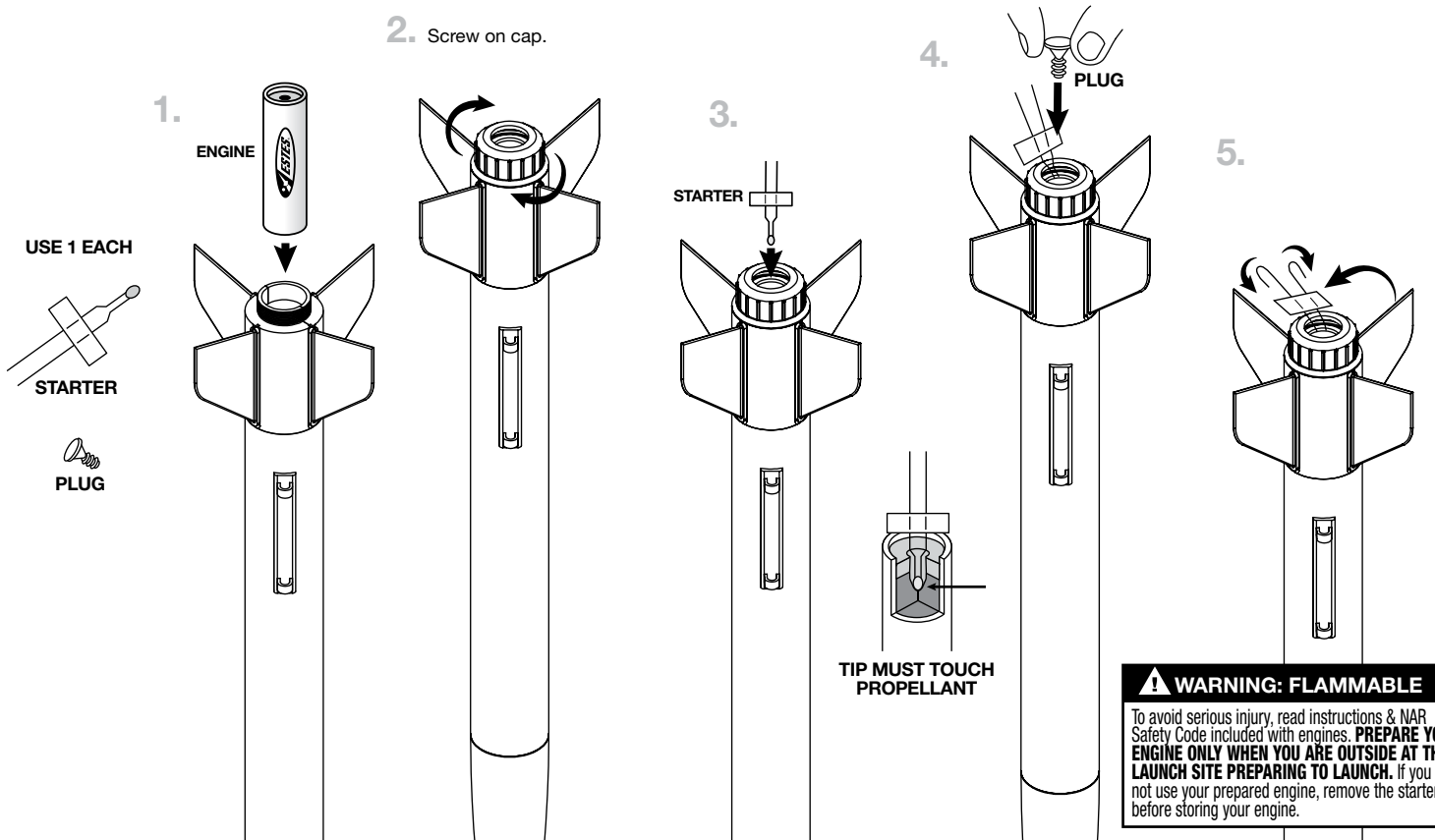

**NOTE:**  
Key always out until final countdown!

**NOTE:**  
Estimated weight: 1.6 oz. (44.4 g)

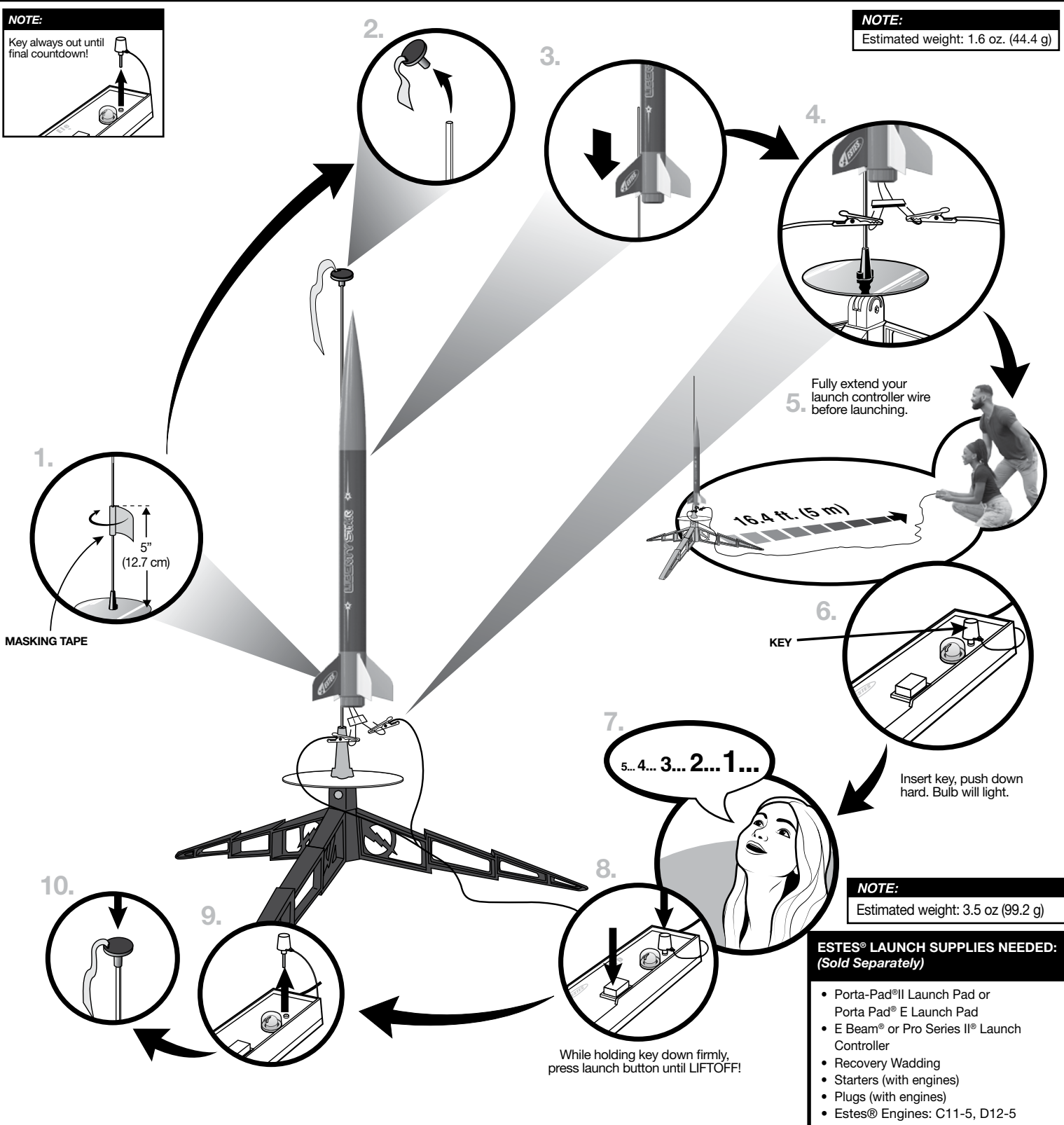

5. Fully extend your launch controller wire before launching.

16.4 ft. (5 m)

**NOTE:**  
Estimated weight: 3.5 oz (99.2 g)

**ESTES® LAUNCH SUPPLIES NEEDED:  
(Sold Separately)**

- Porta-Pad®II Launch Pad or Porta Pad® E Launch Pad
- E Beam® or Pro Series II® Launch Controller
- Recovery Wadding
- Starters (with engines)
- Plugs (with engines)
- Estes® Engines: C11-5, D12-5

While holding key down firmly, press launch button until LIFTOFF!

**PRECAUTIONS**

NAR SAFETY CODE

NO DRY GRASS OR WEEDS

**PRE-LAUNCH CHECK** For safety, never launch a damaged rocket. Check the rocket's body, nose cone and fins. Also, check the engine mount, recovery system and launch lug(s). Repair any damage before launching the rocket.

**FLYING YOUR ROCKET** Choose a large field (500 ft. [152 m] square) free of dry weeds and brown grass. The larger the launch area, the better your chance of recovering your rocket. Launch only with little or no wind and good visibility. Always follow the National Association of Rocketry (NAR) SAFETY CODE (enclosed).

**MISFIRES TAKE THE KEY OUT OF THE CONTROLLER. WAIT ONE MINUTE BEFORE GOING NEAR THE ROCKET.** Disconnect the micro-clips and remove the engine. Take the plug and starter out of the engine. A burned starter means the starter tip was not touching engine propellant. Install a new starter; be sure the tip is touching propellant inside the engine. Push the plug in place. Repeat steps under Countdown and Launch.