



EstesRockets.com

# ORBITRON™

7002

AGES  
10+



Skill Level

**BEGINNER**

## MODEL ROCKET INSTRUCTIONS

KEEP FOR FUTURE REFERENCE

**IMPORTANT: Make sure you have all the parts and supplies. Test fit all the parts for assembly. READ ALL INSTRUCTIONS CAREFULLY.**

### BUILDING SUPPLIES NEEDED



PLASTIC CEMENT



CLEAR TAPE



HOBBY KNIFE

### PARTS

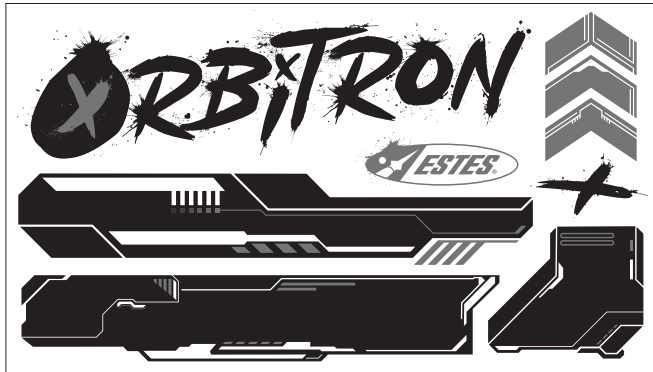

090001-7002  
Decal sheet

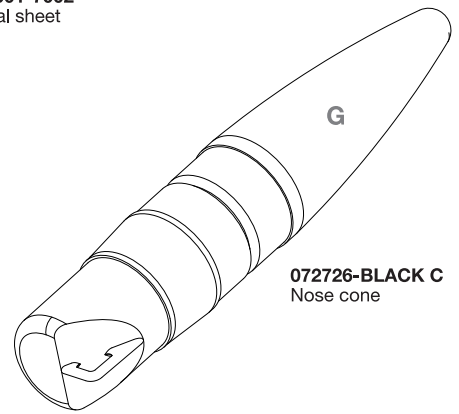

072726-BLACK C  
Nose cone

072939-BLACK C **x4**  
Fin



072936-BLACK C  
Engine Mount A

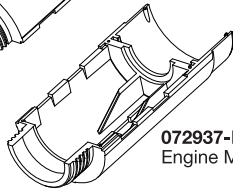
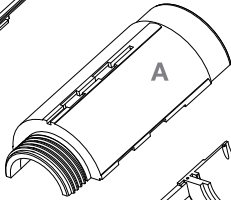

072937-BLACK C  
Engine Mount B



072938-BLACK C  
Engine Retainer Cap

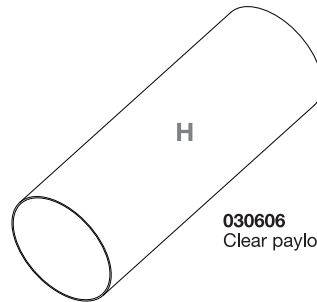

030606  
Clear payload body tube

066459  
Clear reinforcement tape

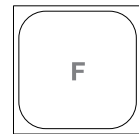

038363  
Shock cord

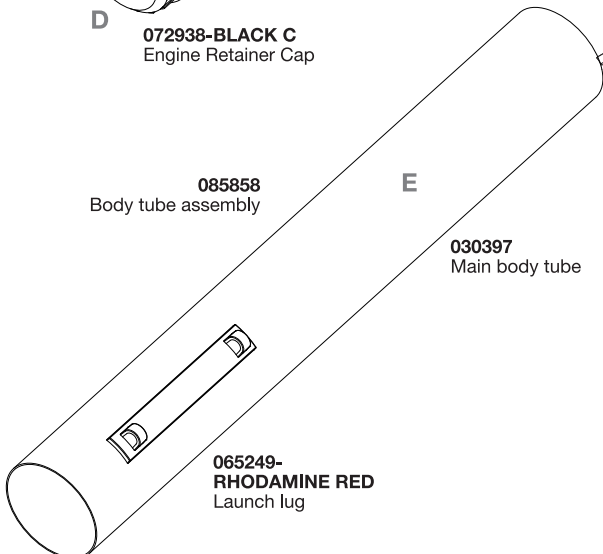

085858  
Body tube assembly

030397  
Main body tube

065249-  
RHODAMINE RED  
Launch lug

035802  
18" Parachute

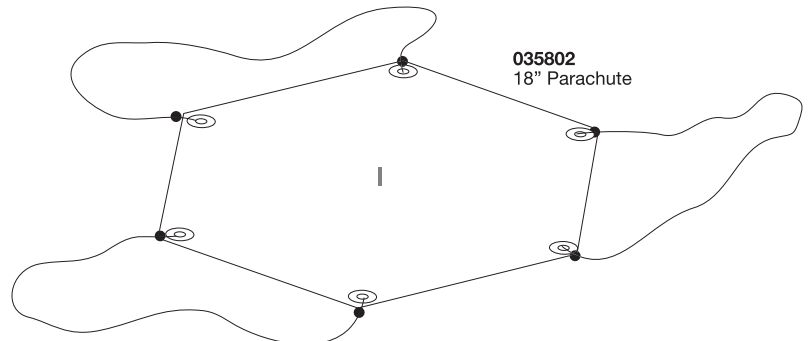

## ASSEMBLE FIN CAN UNIT

1. Apply plastic cement to edges of B.

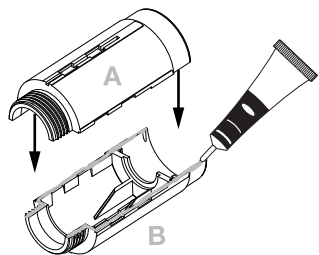

2. Press A and B together and hold for 20 seconds.

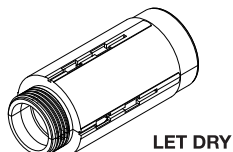

3. Insert fin C into slot and slide forward to lock into place. Repeat for remaining fins.

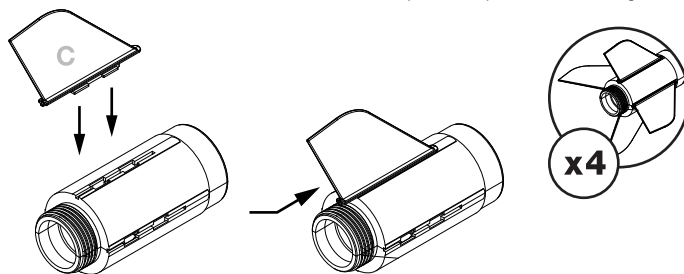

4. Screw engine retainer cap D onto fin can unit.

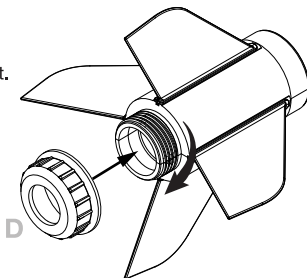

### CAUTION:

For safe handling of plastic cement, see manufacturer's warnings and follow instructions for use.

## ATTACH BODY TUBE

1. Pull shock cord out the front of body tube.

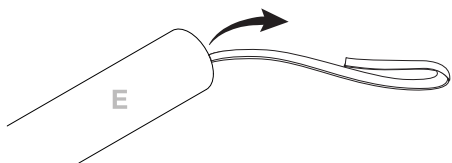

2. Apply plastic cement to inside of body tube E and insert fin can unit. Let dry.

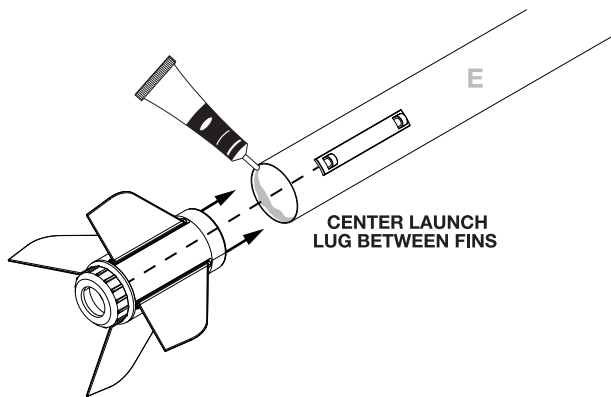

3. Apply clear reinforcement tape over launch lug.

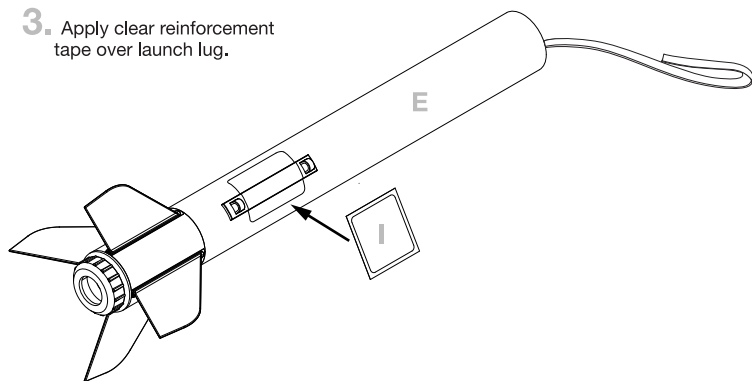

## ASSEMBLE PAYLOAD BAY

1. Hold hobby knife blade in groove of nose cone G. Apply light pressure and rotate nose cone until part separates. Use hobby knife to hollow out eyelet.

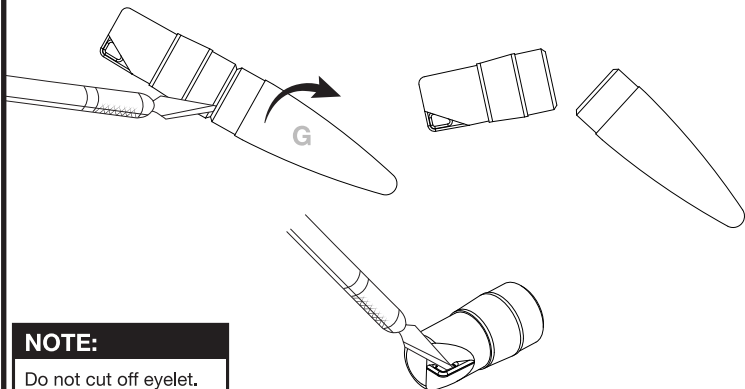

2. If needed, add tape to base of both nose cone pieces and insert pieces into both ends of clear payload tube H.

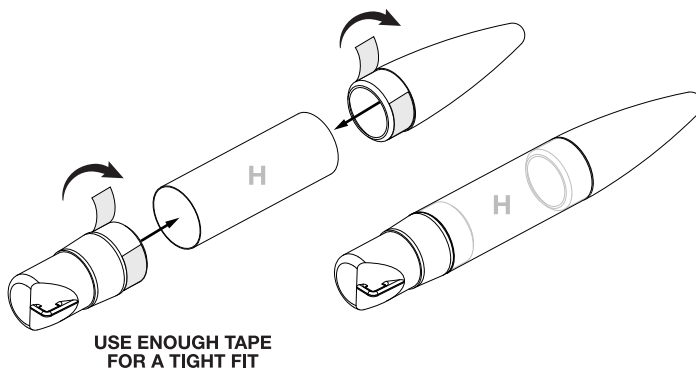

### NOTE:

Do not cut off eyelet.

## ROCKET FINISHING

1. Apply decals as desired.



## PREPARE FLIGHT RECOVERY

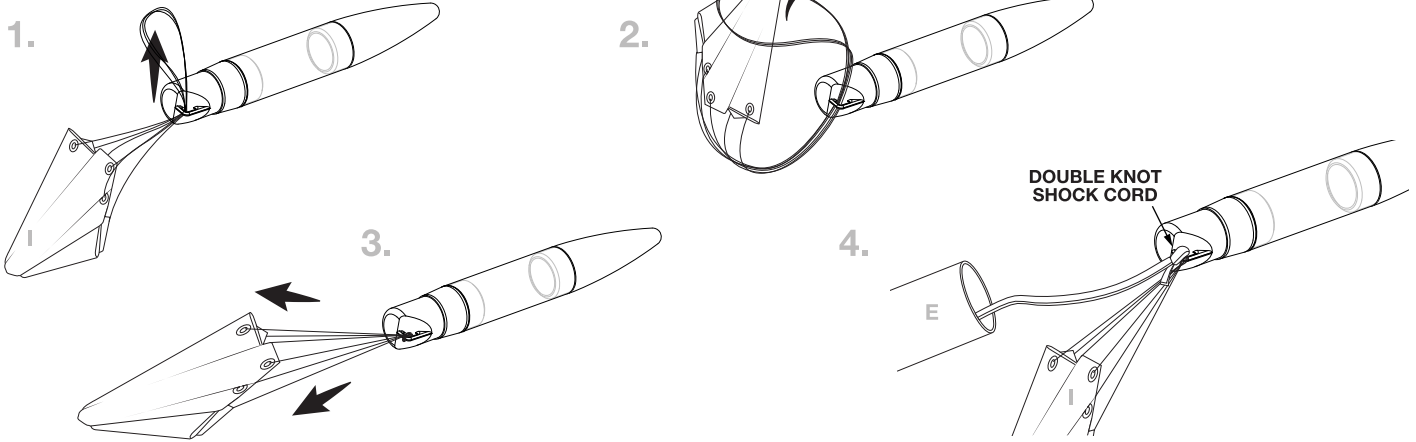

5. Push recovery wadding down towards bottom of body tube E.

6. Fold parachute as shown.

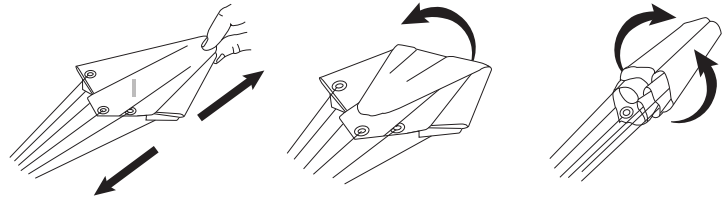
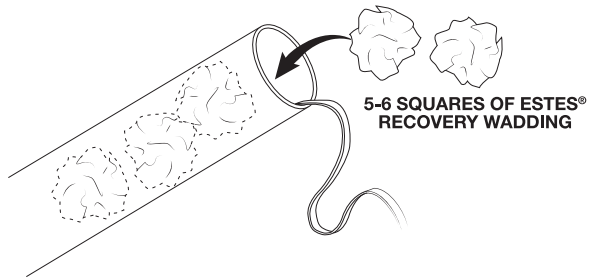

7. Wrap shroud lines loosely around parachute and insert into body tube.

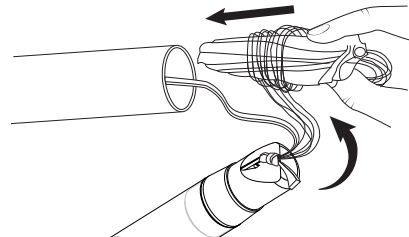

### NOTE:

Recovery wadding and parachute must slide easily into body tube; redo if too tight.

## PREPARE ENGINE

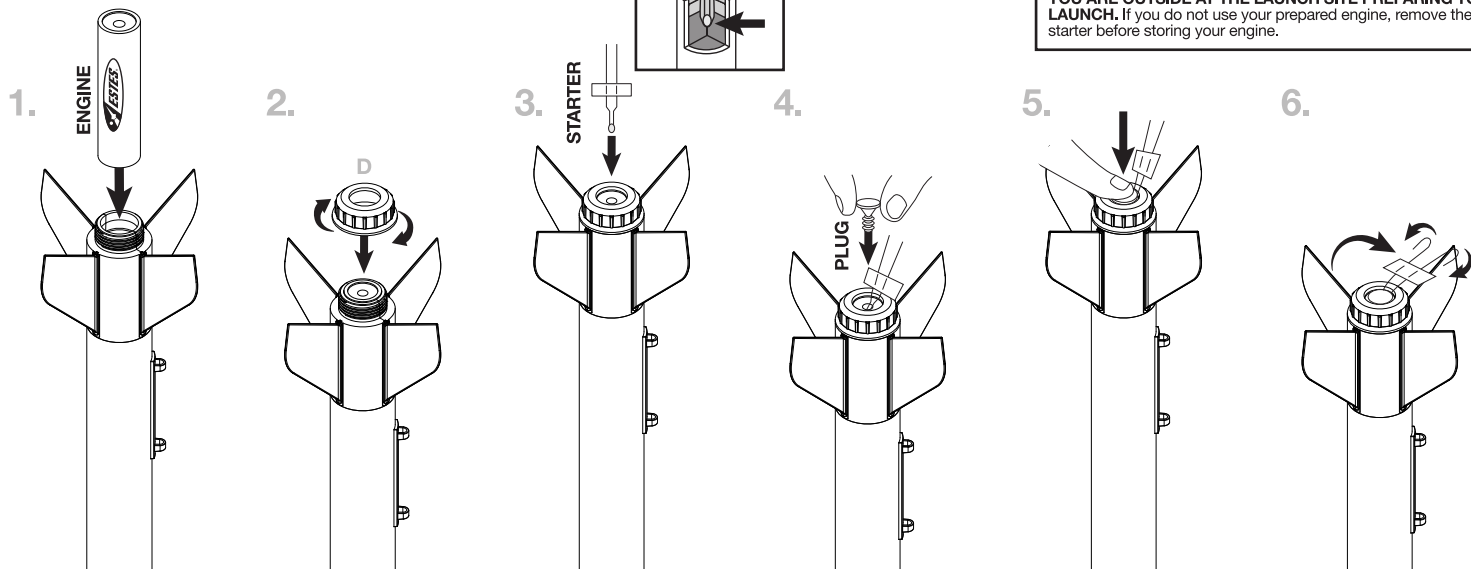

TIP MUST TOUCH PROPELLANT!

**WARNING: FLAMMABLE**

To avoid serious injury, read instructions & NAR Safety Code included with engines. **PREPARE YOUR ENGINE ONLY WHEN YOU ARE OUTSIDE AT THE LAUNCH SITE PREPARING TO LAUNCH.** If you do not use your prepared engine, remove the starter before storing your engine.

# COUNTDOWN AND LAUNCH

**NOTE:**  
Key always out of controller until final countdown!

**NOTE:**  
Estimated weight: 4.3 oz. (122 g)

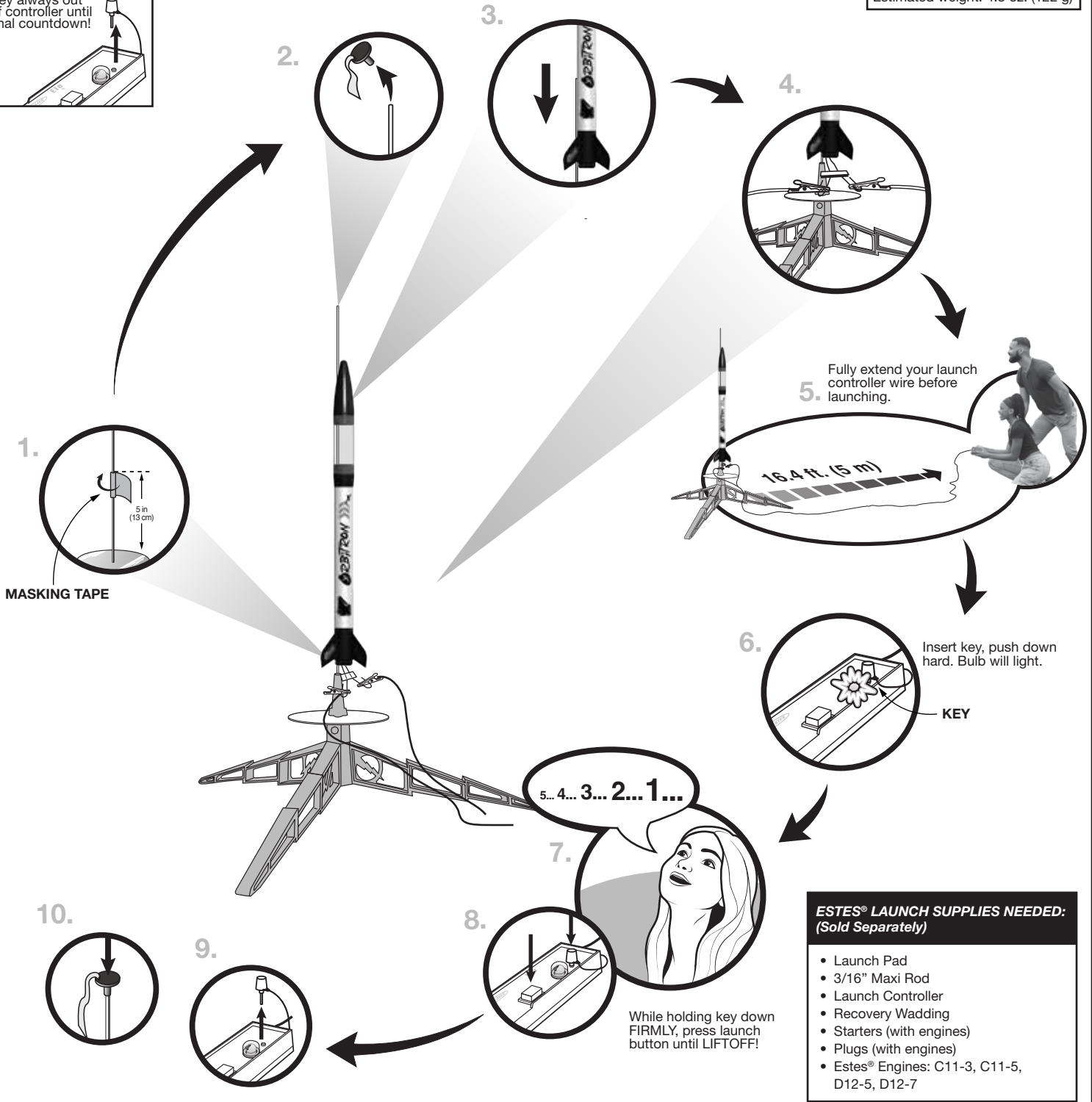

- ESTES® LAUNCH SUPPLIES NEEDED:**  
(Sold Separately)
- Launch Pad
  - 3/16" Maxi Rod
  - Launch Controller
  - Recovery Wadding
  - Starters (with engines)
  - Plugs (with engines)
  - Estes® Engines: C11-3, C11-5, D12-5, D12-7

**PRECAUTIONS**

NAR SAFETY CODE

NO DRY GRASS OR WEEDS

**PRE-LAUNCH CHECK** For safety, never launch a damaged rocket. Check the rocket's body, nose cone and fins. Also, check the engine mount, recovery system and launch lug(s). Repair any damage before launching the rocket.

**FLYING YOUR ROCKET** Choose a large field (500 ft. [152 m] square) free of dry weeds and brown grass. The larger the launch area, the better your chance of recovering your rocket. Launch only with little or no wind and good visibility. Always follow the National Association of Rocketry (NAR) SAFETY CODE (enclosed).

**MISFIRES TAKE THE KEY OUT OF THE CONTROLLER. WAIT ONE MINUTE BEFORE GOING NEAR THE ROCKET.** Disconnect the micro-clips and remove the engine. Take the plug and starter out of the engine. A burned starter means the starter tip was not touching engine propellant. Install a new starter; be sure the tip is touching propellant inside the engine. Push the plug in place. Repeat steps under Countdown and Launch.