



www.estesrockets.com

ESTES® INDUSTRIES  
1295 H Street  
Penrose, CO 81240  
PRINTED IN CHINA

NO.2

# Sky Writer™

FOR KITS:  
EST 1235  
EST 1260

FLYING MODEL ROCKET KIT INSTRUCTIONS  
KEEP FOR FUTURE REFERENCE.

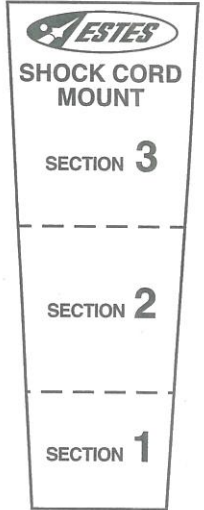

## ASSEMBLY TIP

Read all instructions before beginning work on your model. Make sure you have all parts and supplies. **TEST-FIT ALL PARTS TOGETHER BEFORE APPLYING ANY GLUE.** If any parts don't fit properly, sand as required for precision assembly.

## PARTS:

Locate the parts shown below and lay them out on the table in front of you. **DO NOT USE THIS DRAWING TO ASSEMBLE YOUR ROCKET.**

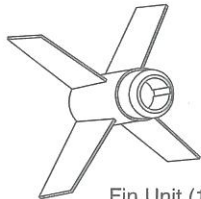
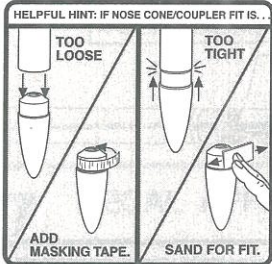

Fin Unit (1)  
72614

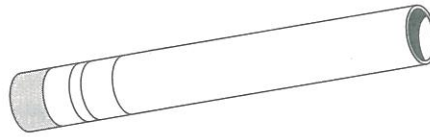

Lower Body Tube - BT-50 (1)  
(60158)

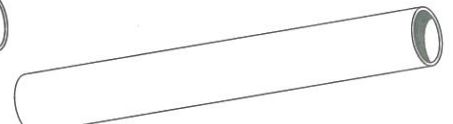

Upper Body Tube - BT-50 (1)  
(30349)



Blue Engine Mount Tube (1)  
(30326-1)



Green Engine Block (1)  
(30162-2)



Black Engine Holder Ring (1)  
(30120-3)



Nose Cone (1)  
(71027)



Green Adaptor Ring (1)  
(30165-2)



Launch Lug (1)  
(38175)



Decal Sheet (1)  
(60160)

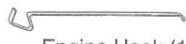

Engine Hook (1)  
(35021)

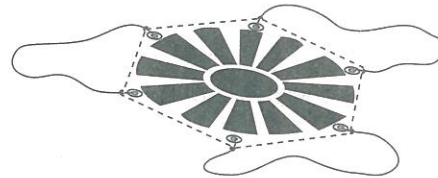

Assembled 12" (30 cm) Parachute  
(35801)



Shock Cord (1)  
(38374)



Red Tube Coupler (1)  
(30174-5)

## SUPPLIES REQUIRED:



HOBBY KNIFE



PLASTIC CEMENT



CARPENTER'S GLUE



SPRAY CLEAR COAT (OPTIONAL)



PENCIL



RULER



SCISSORS



FINE SAND PAPER (#400-600 GRIT)



MASKING TAPE

ALL GLUED AREAS ARE SHADED IN GRAY

# 1. ENGINE MOUNT ASSEMBLY

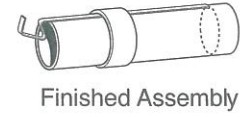
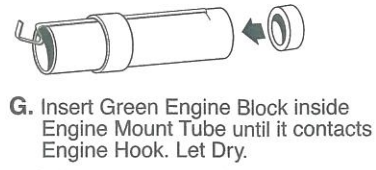
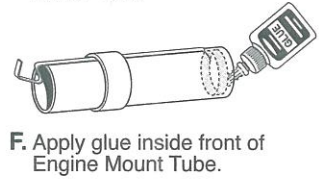
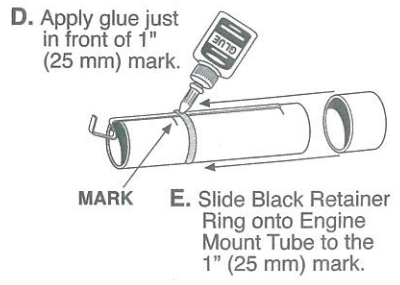
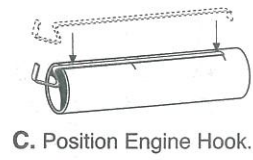
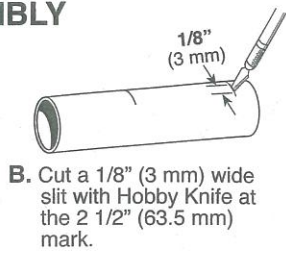
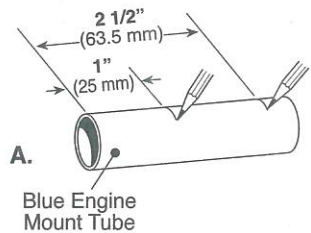

# 2. FIN UNIT ASSEMBLY

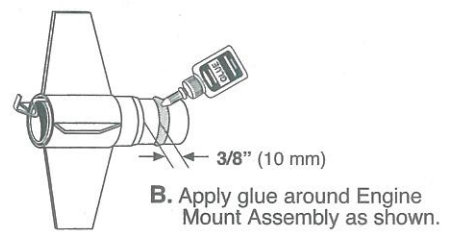
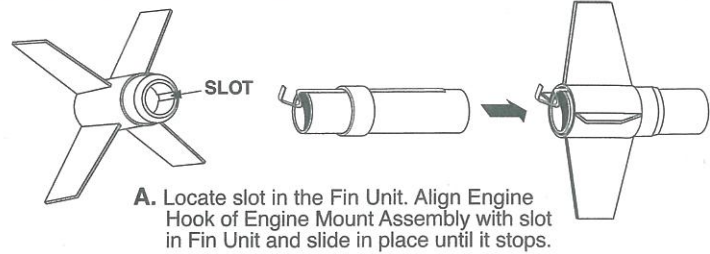

**C.** Hold Engine Mount Assembly in place with thumb. In one continuous movement slide Green Adapter Ring onto Engine Mount until it touches Fin Unit. Let glue dry.

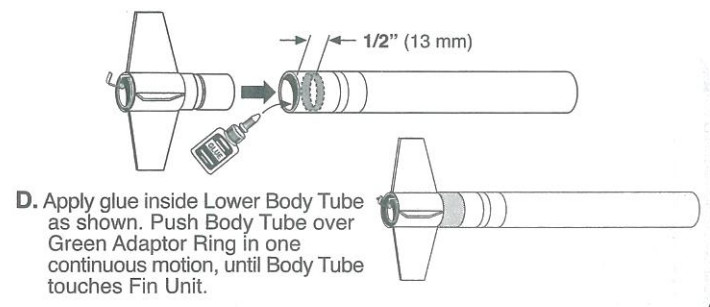
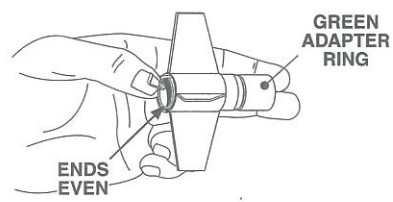

# 3. BODY TUBE ASSEMBLY

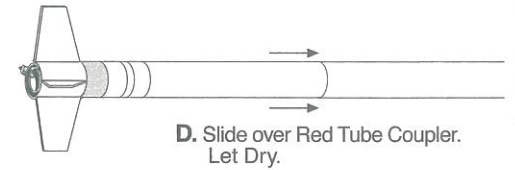
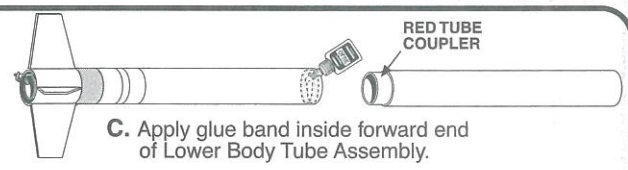
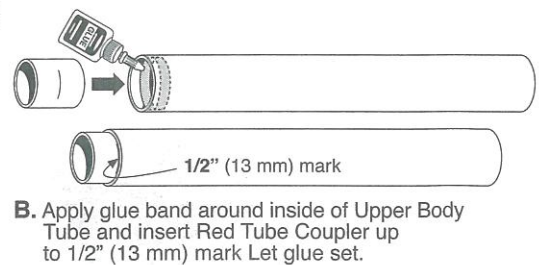
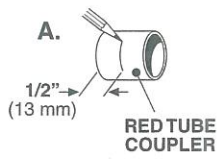

# 4. ATTACHING LAUNCH LUG

