

BOEING A.L.C.M. CRUISE MISSILE

SKILL LEVEL 4 – Recommended for Advanced Rocketeers.

RECOMMENDED ENGINES:
A8-3 B4-4 B6-4 B8-5 B14-5 C6-5

BEFORE YOU START

Read all instructions before beginning work on your model. Make sure you have all parts and materials. When you are thoroughly familiar with the assembly procedure, begin construction. Check off each step as you complete it. In each step test-fit the parts together before applying any glue. If some part doesn't fit properly, sand lightly or build up as required for precision assembly.

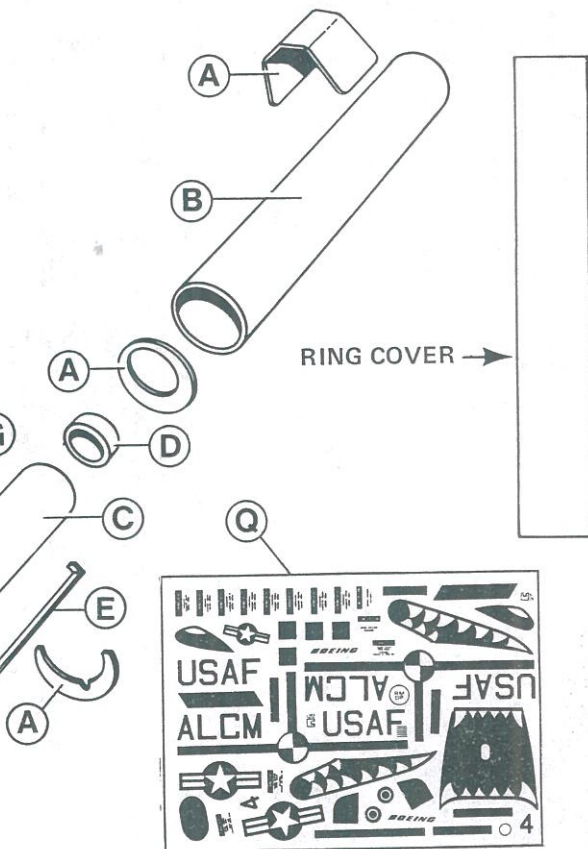
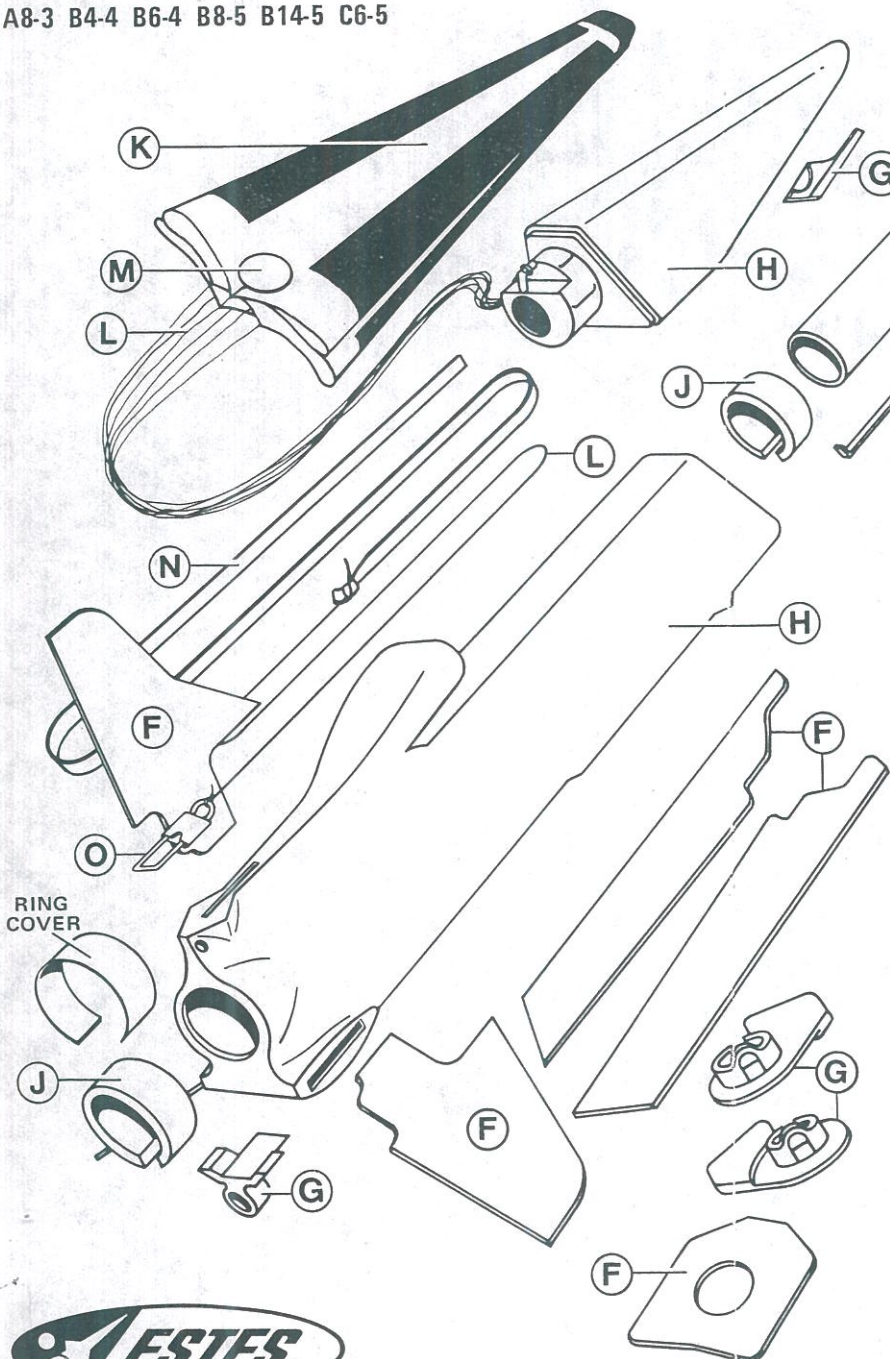

KIT NO. 1336 PARTS LIST

A	1 Die-Cut Card (type TA-1336)	32922
B	1 Parachute Tube (type ST-106)	31135
C	1 Engine Tube (type ST-73)	31038
D	1 Engine Block (type TR-7A)	30155
E	1 Engine Hook (type EH-2)	35025
F	1 Die-Cut Plastic Sheet (type PL-1336)	33205
G	1 Plastic Hinge/Lug Set	33200
H	1 Molded Missile Body & Nose Cone	33201
I	1 Clay Weight (Not Shown)	85264
J	2 Centering Rings (type CR-78)	30140
K	1 Parachute (type PK-12)	85564
L	1 Shroud Line (type SLT-72)	38237
M	1 Tape Discs (type TD-3F)	38406
N	1 Shock Cord (type SC-1)	85730
O	1 Snap Swivel (type SV-2)	38269
P	1 Contact Cement Capsule (Not Shown)	37828
Q	1 Decal (type KD-1336)	36842

TOOLS AND MATERIALS

In addition to the parts included in this kit you will need white glue (Titebond, Elmer's, or similar household white glue is recommended.), scissors, pencil, ruler, fine and extra-fine grit sandpaper, masking tape, tube-type plastic cement, modeling knife with sharp blade, razor saw, tweezers, rubber bands, wax paper, and white enamel spray paint.



ESTES INDUSTRIES
PENROSE, CO 81240 USA