

# US5 HYPERION

SKILL LEVEL 3 - Recommended for Craftsman Rocketeers.

## BEFORE YOU START

Read each step and study the accompanying drawings before doing any of the work called for in that step. Make sure you have all parts and materials. Check off each step as you complete it. Always test-fit parts together before applying glue. It will sometimes be necessary to sand edges of rings, tubes, etc. to obtain a proper fit. If you are in doubt about the relative size or location of some parts, refer back to this exploded view drawing for clarification. Adequate glue joints are very important for a flying model rocket. Follow the instructions carefully in this regard.

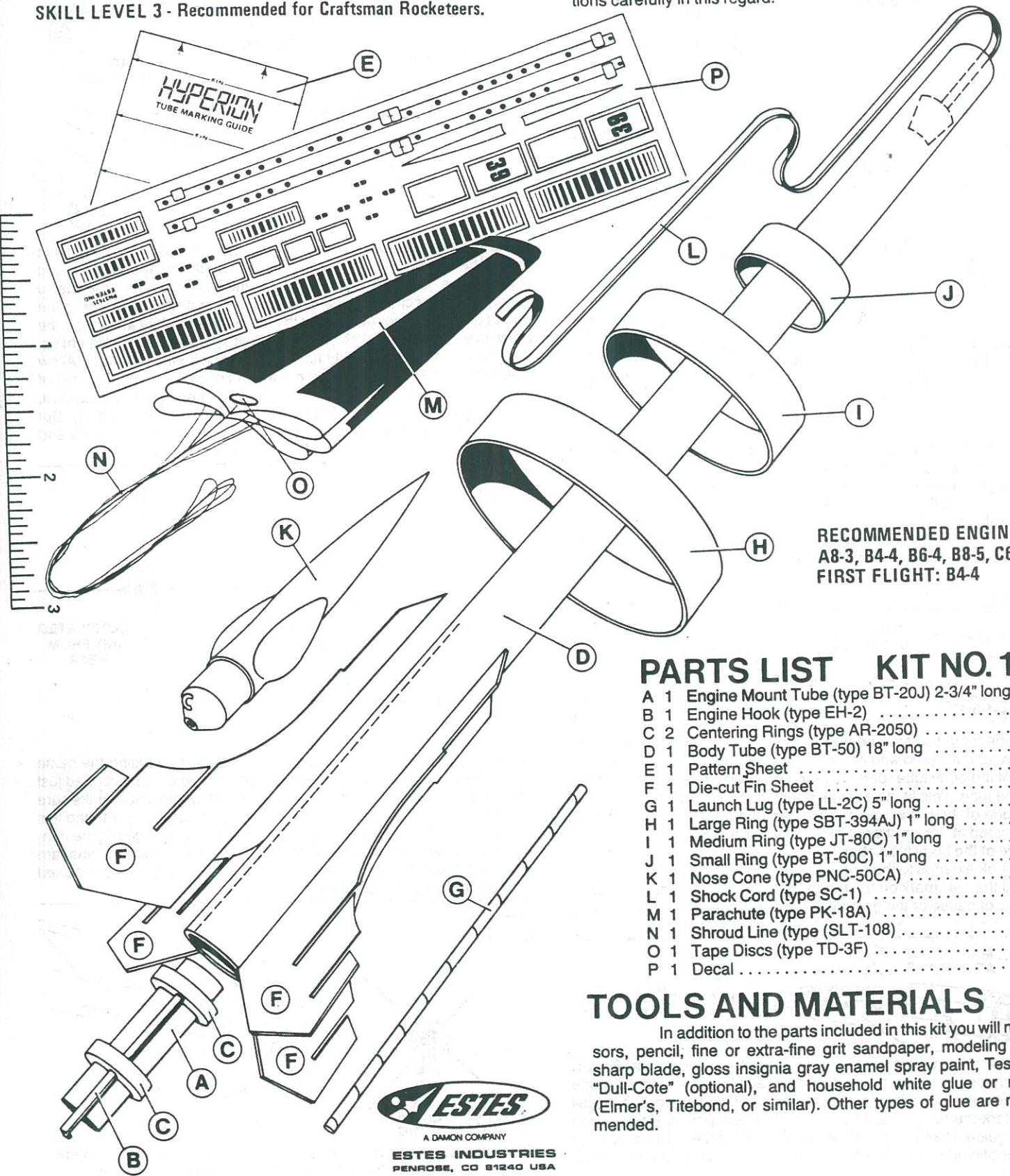

**RECOMMENDED ENGINES:**  
A8-3, B4-4, B6-4, B8-5, C6-5  
**FIRST FLIGHT: B4-4**

## PARTS LIST KIT NO. 1383

A	1	Engine Mount Tube (type BT-20J) 2-3/4" long	30326
B	1	Engine Hook (type EH-2)	35025
C	2	Centering Rings (type AR-2050)	30164
D	1	Body Tube (type BT-50) 18" long	30352
E	1	Pattern Sheet	83418
F	1	Die-cut Fin Sheet	32463
G	1	Launch Lug (type LL-2C) 5" long	38180
H	1	Large Ring (type SBT-394AJ) 1" long	30449
I	1	Medium Ring (type JT-80C) 1" long	30274
J	1	Small Ring (type BT-60C) 1" long	30405
K	1	Nose Cone (type PNC-50CA)	71005
L	1	Shock Cord (type SC-1)	85730
M	1	Parachute (type PK-18A)	85566
N	1	Shroud Line (type (SLT-108)	38239
O	1	Tape Discs (type TD-3F)	38406
P	1	Decal	37525

## TOOLS AND MATERIALS

In addition to the parts included in this kit you will need: Scissors, pencil, fine or extra-fine grit sandpaper, modeling knife with sharp blade, gloss insignia gray enamel spray paint, Testors spray "Dull-Cote" (optional), and household white glue or resin glue (Elmer's, Titebond, or similar). Other types of glue are not recommended.



A DAMON COMPANY  
**ESTES INDUSTRIES**  
PENROSE, CO 81240 USA