



ESTES INDUSTRIES (6-97) 84389
 1295 H Street EST 1449
 Penrose, CO 81240

ERX
 SERIES
 ALMOST READY TO FLY

SUPER SHOT™

FLYING MODEL ROCKET KIT INSTRUCTIONS

TOOLS REQUIRED: SCISSORS, PENCIL, HOBBY KNIFE, TUBE-TYPE PLASTIC CEMENT
 ALL GLUED AREAS ARE SHADED IN GRAY

PARTS LAYOUT

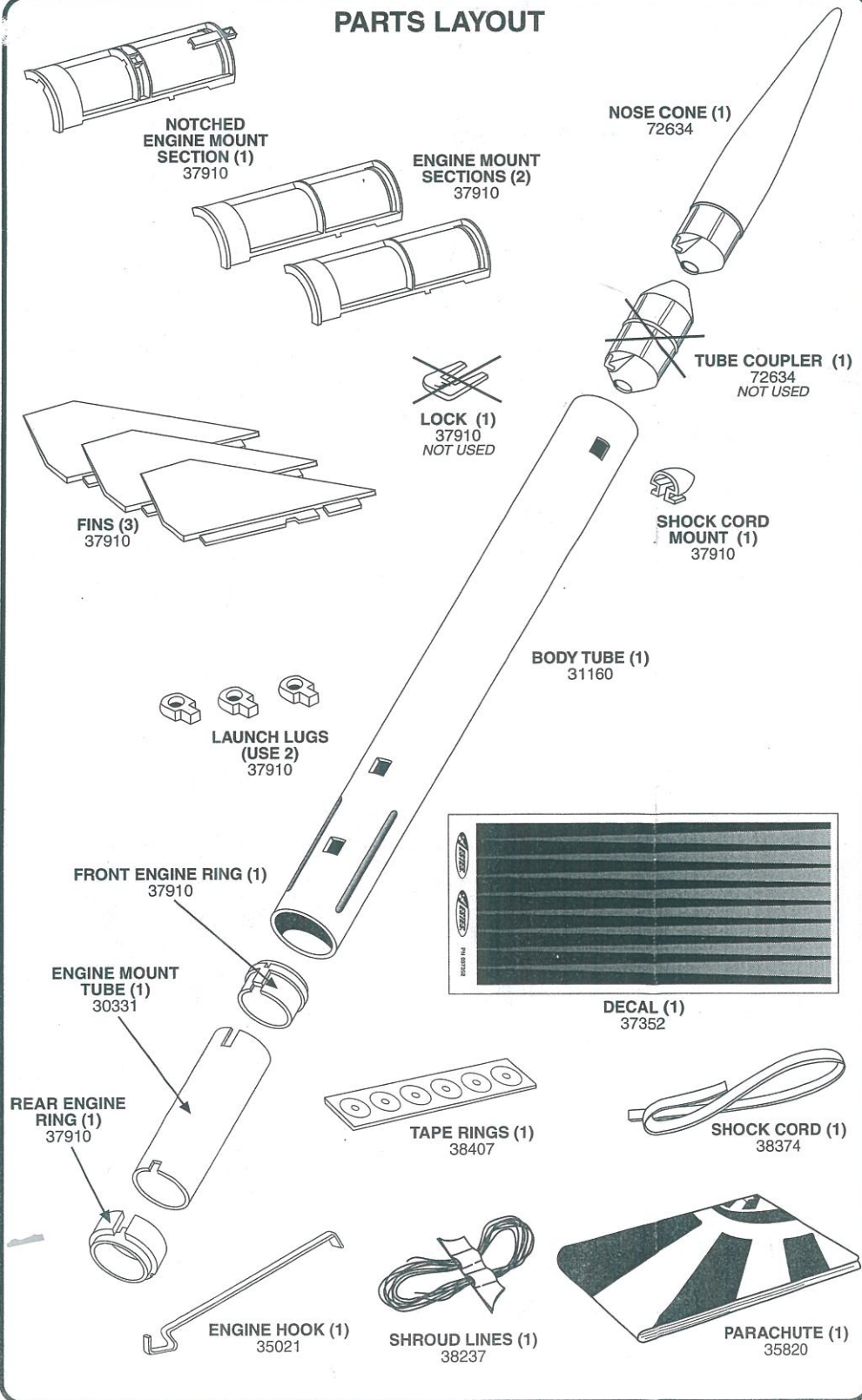

1. A. Apply plastic cement as shown a slide front ring inside tube. Line with long notch.

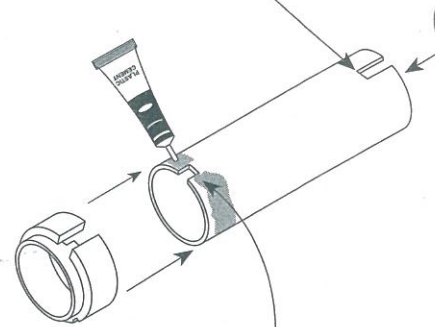

B. Slide back ring over tube. Line up with short notch.

2. IMPORTANT! LINE UP LAUNCH LUG OPENINGS!

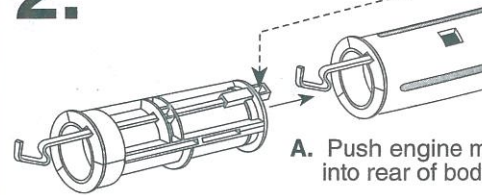

A. Push engine m into rear of body

THIS NOTCH GC FRONT. TEST FI BEFORE GLUIN

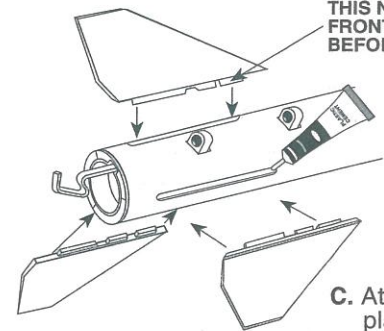

C. Attach fins plastic cer

5.

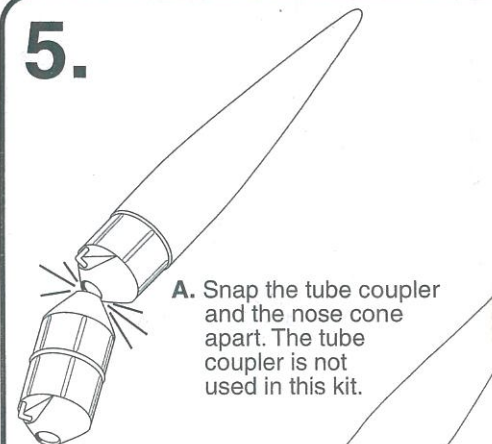

A. Snap the tube coupler and the nose cone apart. The tube coupler is not used in this kit.

B. C

IMPORTANT! THIS NOTCH GOES OVER ENGINE HOOK

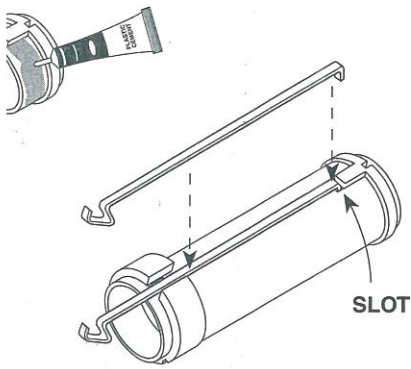

C. Attach engine hook. Push front tab through slot in tube.

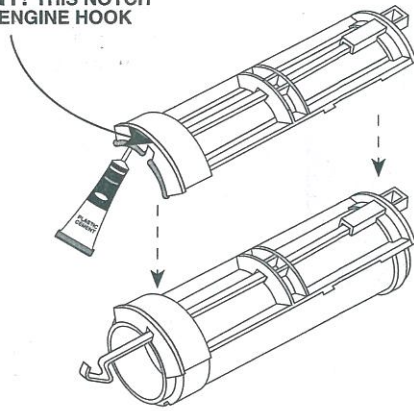

D. Apply cement to underside of **notched** engine mount section and attach.

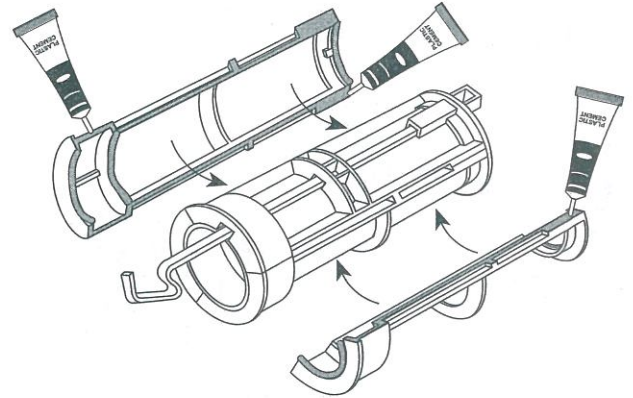

E. Now attach the remaining sections with cement as shown.

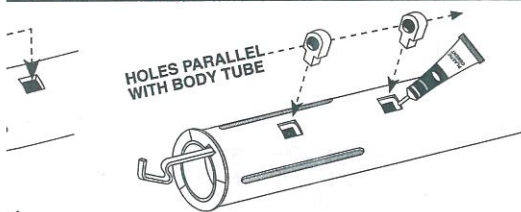

B. Attach launch lugs with plastic cement.

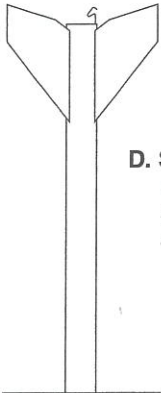

D. Set rocket on table as shown so fins will stay straight while cement sets.

3.

A. Cut out parachute on dotted line.



B. Find shroud line material. Remove tape. Using all the string, fold and cut into three equal lengths.



C. Press tape rings on marks on corners.



D. Punch holes with sharp pencil.



E. Tie lines off with double knots.



COMPLETED PARACHUTE

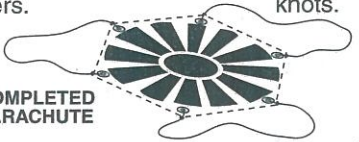

4.

A. Locate elastic shock cord and shock cord mount.



B. Apply plastic cement to shock cord mount as shown. Attach to body tube through square hole.

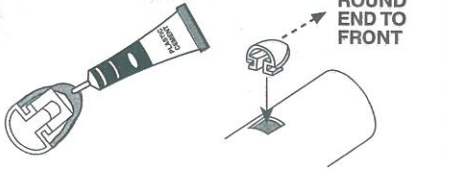

C. Tie double knot in end of shock cord. Push other end through until knot is tight against shock cord mount.

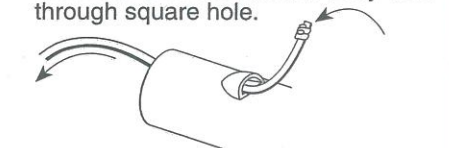

ROUND END TO FRONT

6.

A. Form loop with shroud lines.

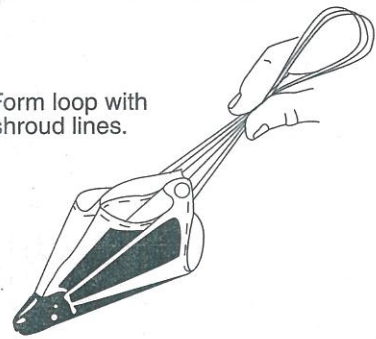

B. Push loop through eye of nose cone.

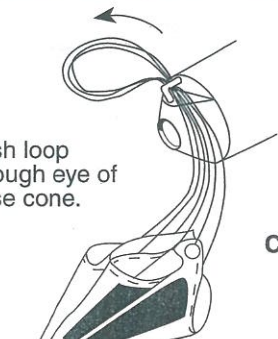

C. Pass parachute through loop.

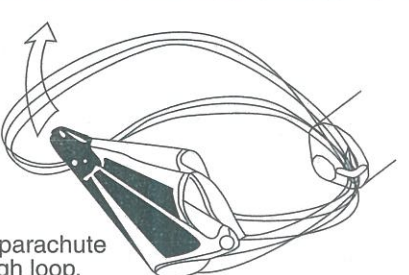

D. Pull tight.

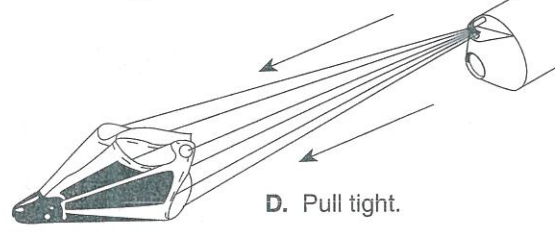

E. Tie shock cord to nose cone with a double knot.

