

EXOCET MM 38 *aerospatiale*

SKILL LEVEL 3 - Recommended for Craftsman Rocketeers.



A DAMON COMPANY

ESTES INDUSTRIES
PENROSE, CO 81240 USA

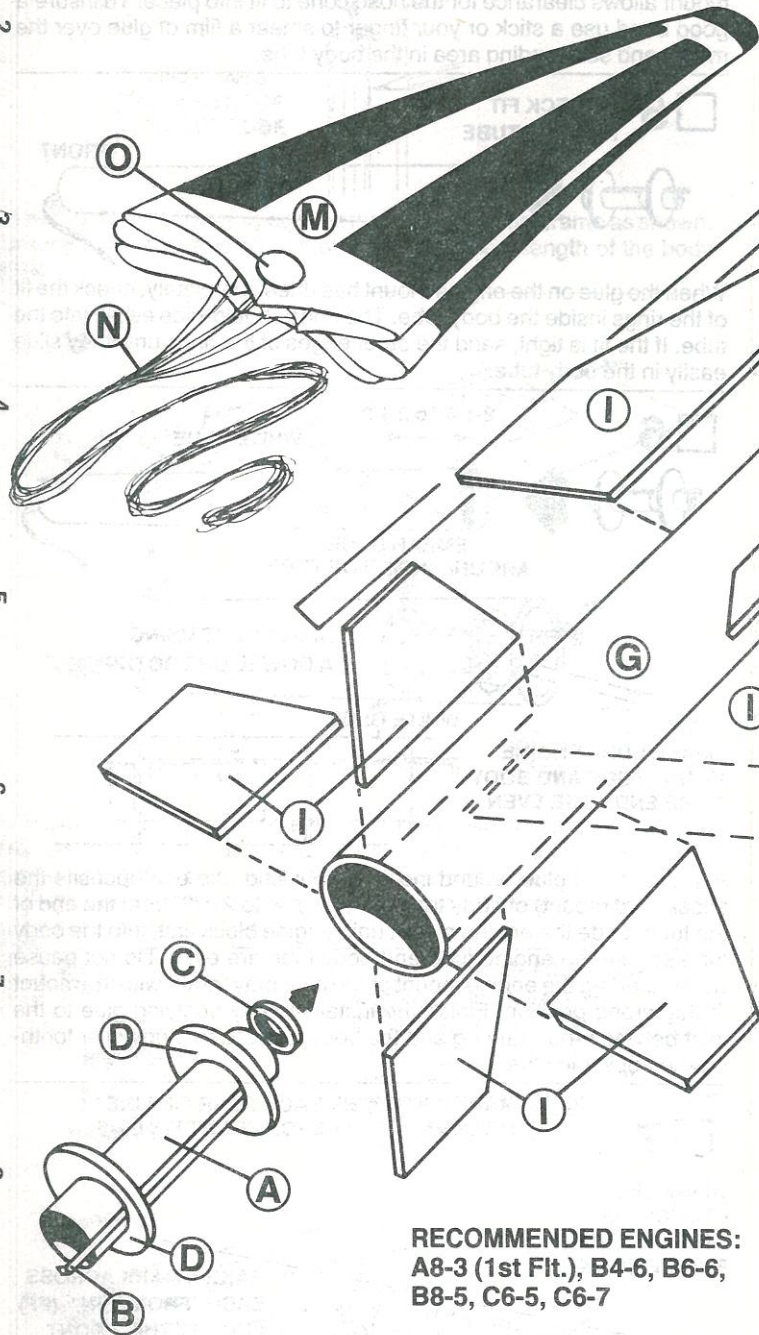

RECOMMENDED ENGINES:
A8-3 (1st Flt.), B4-6, B6-6,
B8-5, C6-5, C6-7

TOOLS AND MATERIALS

In addition to the parts included in this kit you will need: Scissors, household white glue (Elmer's, Titebond, or similar), pencil, ruler, fine or extra-fine grit sandpaper, sanding sealer, a medium-size modeling paint brush, modeling knife with sharp blade. Gloss white, gloss black & insignia orange spray enamel, and Dull Cote spray.

For easy and positive alignment of the rear fins on your model, we recommend the use of Estes' Fin Alignment Guide, Part No. 2231.

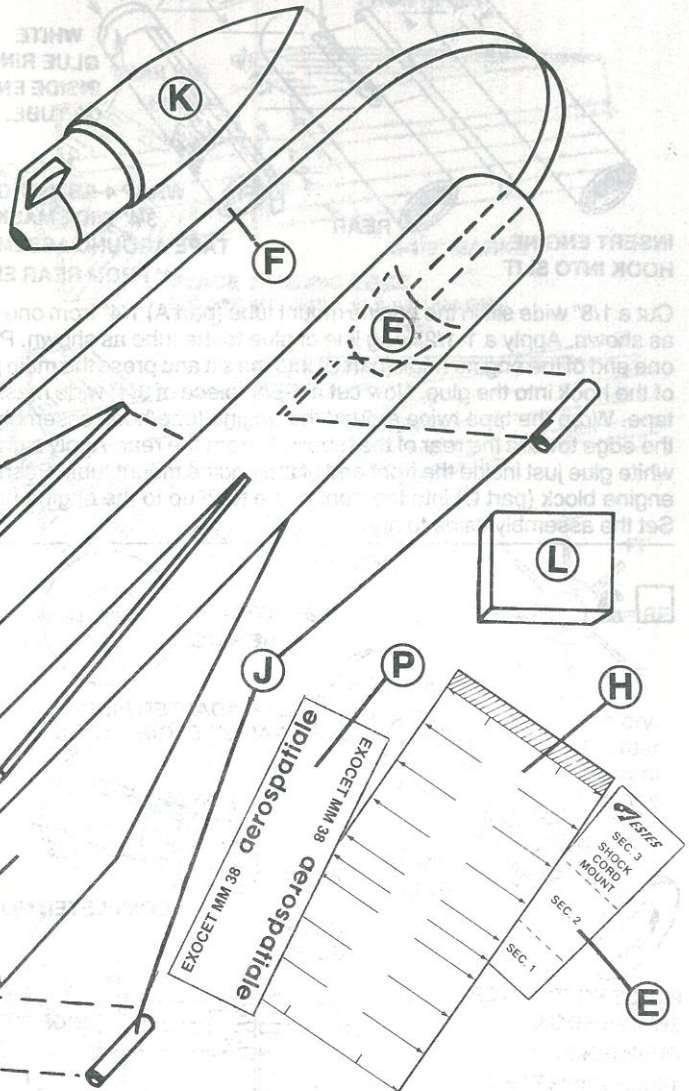

BEFORE YOU START

Read all instructions before beginning construction on your model. Make sure you have all parts and materials. When you are thoroughly familiar with the assembly procedure, begin construction. Check off each step as you complete it. In each step, test-fit the parts together before applying any glue. If some part doesn't fit properly, sand lightly or build up as required for precision assembly.

PARTS LIST KIT NO. 1925

A	1	Engine Mount Tube (BT-20J)	30326
B	1	Engine Hook (EH-2)	35025
C	1	Engine Block (AR-520)	30162
D	1	Adapter Ring Set (TA-1327)	30090
E	1	Shock Cord Mount	on page 5 of inst.
F	1	Shock Cord (SC-1)	85730
G	1	Body Tube (BT-55)	30382
H	1	Body Tube Marking Guide	on page 5
I	1	Die-Cut Balsa Fin Sheet	32625
J	1	Launch Lug (LL-2A)	38175
K	1	Plastic Nose Cone (PNC-55 EX)	71031
L	1	Clay Balance Weight	85264
M	1	Parachute (PK-12A)	85564
N	1	Shroud Line (SLT-T2)	38237
O	1	Tape Discs Set (TD-3F)	38406
P	1	Decal (KD-1925)	37240

