



ESTES INDUSTRIES
1295 H Street
Penrose, CO 81240



ALMOST READY TO FLY

82108
(12-97)
EST 2131

Mk-109 STINGRAY™

FLYING MODEL ROCKET KIT INSTRUCTIONS

TOOLS REQUIRED: SCISSORS, PENCIL, HOBBY KNIFE, SMALL PHILLIPS HEAD SCREWDRIVER, TUBE-TYPE PLASTIC CEMENT

ALL GLUED AREAS ARE SHADED IN GRAY

PARTS LAYOUT

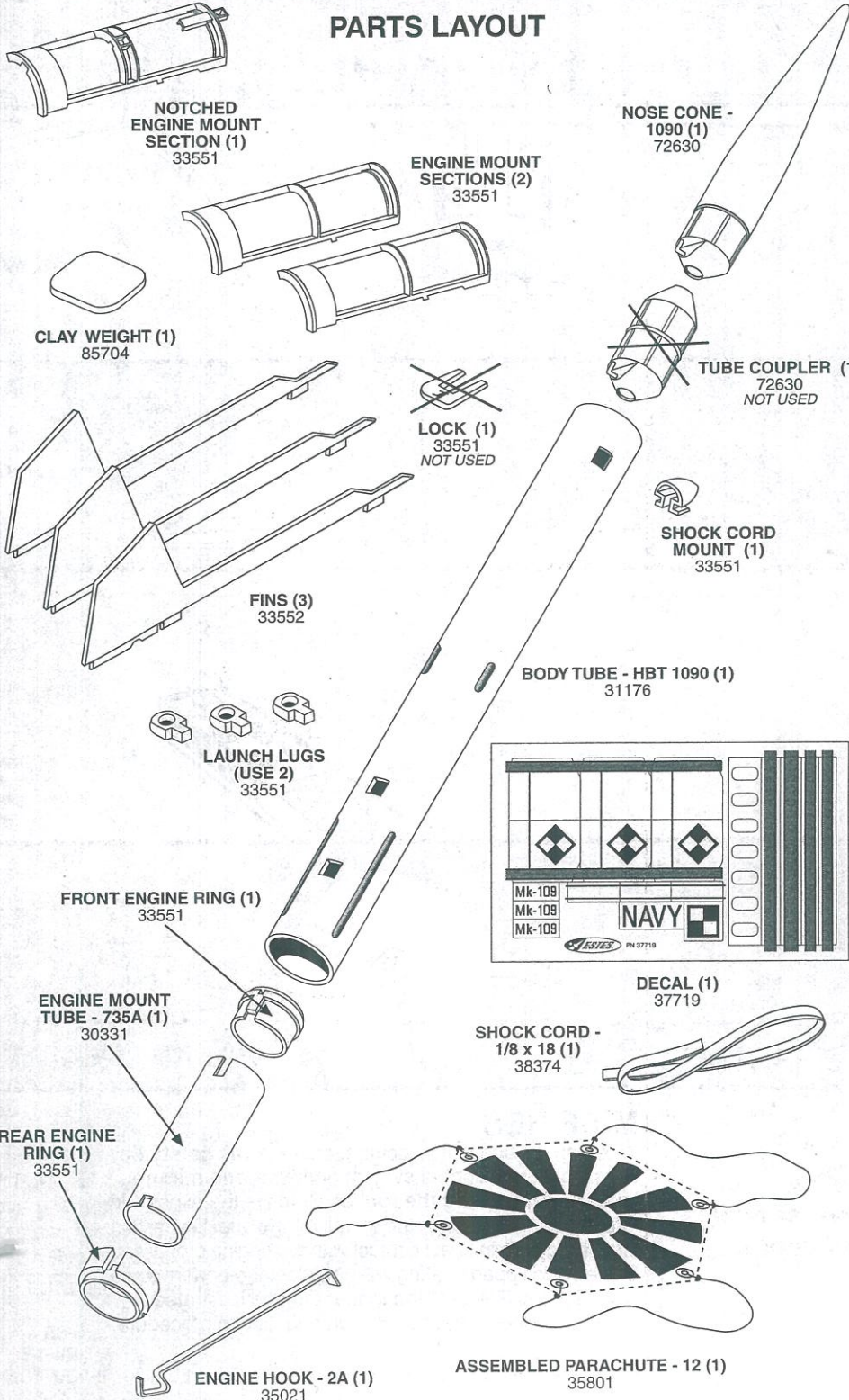

1. A. Apply plastic cement as shown to slide front engine ring inside engine mount tube. Line up with long notch.

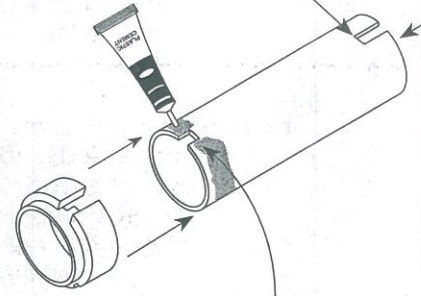

B. Slide rear engine ring over tube. Line up with short notch.

2. IMPORTANT! LINE UP LAUNCH LUG OPENINGS!

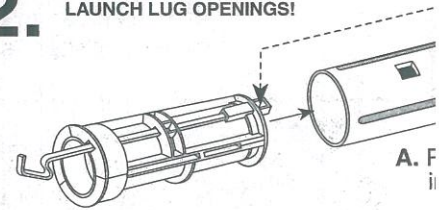

THIS NOTCH FRONT. TEST BEFORE GLUE

4.

A. Snap tube coupler off of the nose cone and discard.

B. Roll clay weight "snakes", drop nose cone, and a small phillips head screwdriver press clay into cone tip.

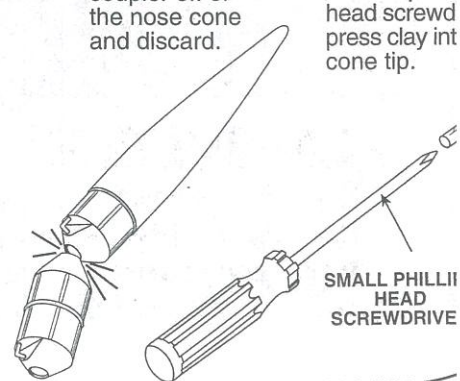

CAREFUL! DO NOT CUT OFF THIS PIECE

IMPORTANT! THIS NOTCH GOES OVER ENGINE HOOK

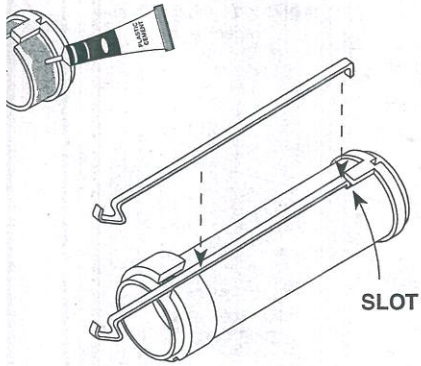

C. Attach engine hook. Push front tab through slot in tube.

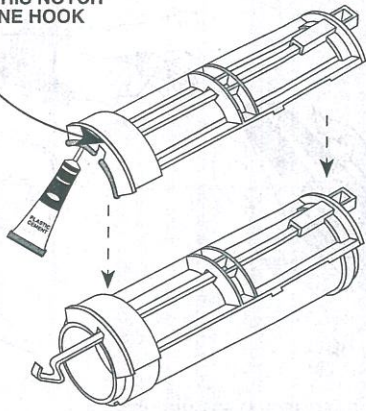

D. Apply cement to underside of notched engine mount section and attach.

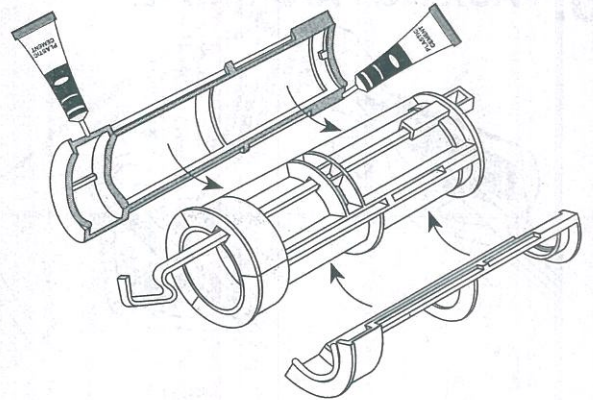

E. Now attach the remaining sections with cement as shown.



h engine mount rear of body tube.



ESTO T G.

C. Apply plastic cement along the root edges of the fins, and apply making sure each fin is seated in both slots.

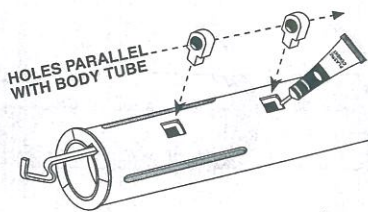

B. Attach launch lugs with plastic cement.

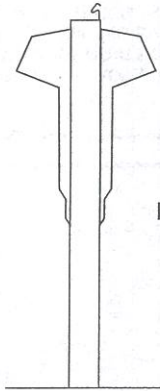

D. Set rocket on table as shown so fins will stay straight while cement sets.

3.

A. Locate elastic shock cord and shock cord mount.

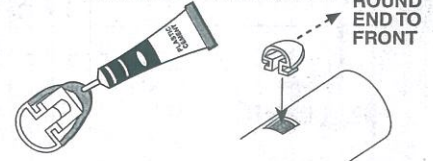

ROUND END TO FRONT

B. Apply plastic cement to the bottom of the shock cord mount as shown. Attach to body tube through square hole. Let dry.

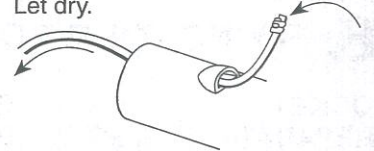

C. Tie double knot in end of shock cord. Thread other end through until knot is tight against shock cord mount.

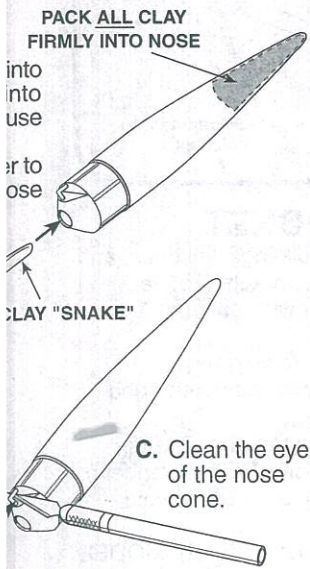

PACK ALL CLAY FIRMLY INTO NOSE

into into use er to ose

CLAY "SNAKE"

C. Clean the eye of the nose cone.

5.

A. Form loop with parachute shroud lines.

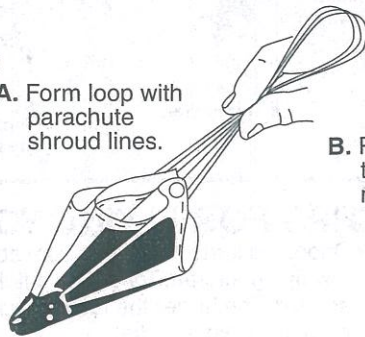

B. Push loop through eye of nose cone.

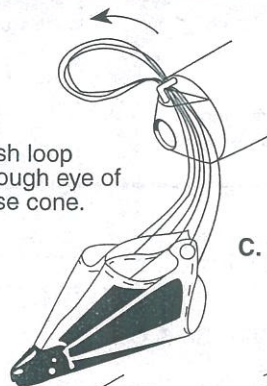

C. Pass parachute through loop.

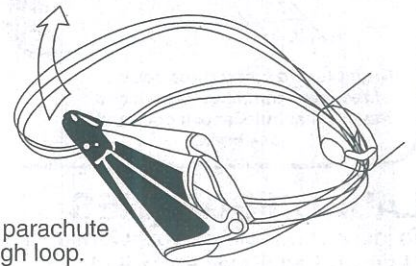

D. Pull tight.

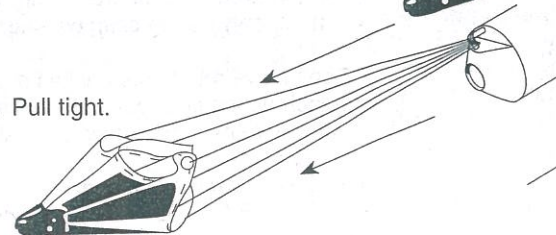

E. Tie shock cord to the eye of the nose cone with a double knot.

